READ & FOLLOW ALL
INSTRUCTIONS,
WARNINGS & CAUTIONS
BEFORE USING THIS VACUUM.

SAFETY,
OPERATION
MANUAL
w/PARTS LIST



ENVIROMASTER 9
HEPA DRY
VACUUM
CLEANER

This unit is intended for commercial use.

This vacuum will afford you many years of trouble-free operating satisfaction, provided it is given proper care. All parts have passed rigid quality control standards prior to their being assembled to produce the finished product. Prior to packaging, your vacuum was again inspected for assurance of flawless assembly.

This vacuum is protectively packed to prevent damage in shipment. We recommend that upon delivery, unpack the unit and inspect it for any possible damage. Only a visual examination will reveal damage that may have occurred.

If damage is discovered, immediately notify the transportation company that delivered your vacuum. As a shipper, we are unable to

report any claim for damage. You must originate any claim within 5 days.

This manual is for your protection and information. **PLEASE READ CAREFULLY** since failure to follow precautions could result in discomfort or injury. Read this manual completely before operating this vacuum. It is important to follow the instructions in the manual to prevent the possibility of injury or damage to the user and/or machine.

Treat your vacuum cleaner as you would any other high grade precision made product. Dropping, unreasonable bumping across thresholds and other misuses may result in a damaged unit that will not be covered by warranty.

PLEASE READ
CAREFULLY
BEFORE
OPERATING

SAVE THESE INSTRUCTIONS

IMPORTANT SAFETY INSTRUCTIONS

WARNING:

To Reduce the Risk of Fire, Electric Shock or Injury:
Electric shock could occur if used on wet surfaces.
DO NOT expose to rain. Store indoors.

When using this vacuum basic precautions should always be followed, including the following:

1. **DO NOT** leave the vacuum when plugged in. Unplug from the outlet when not in use and before servicing.
2. To avoid electric shock, **DO NOT** expose to rain. Store indoors. **DO NOT** use on wet surfaces.
3. This is **NOT** a toy. Close attention is necessary when used around or near children.
4. Use only as described in this safety manual. Use only the manufacturer's recommended attachments and accessories.
5. **DO NOT** use this vacuum with damaged cord or plug. If the vacuum is not working as it should, because it has been dropped, damaged, left outdoors or dropped into water, contact an authorized service center or factory.
6. **DO NOT** unplug the vacuum by pulling on the cord. To unplug, grasp the plug, not the cord.
7. **DO NOT** pull or carry by the cord, use cord as a handle, close a door on cord or pull cord around sharp edges and corners. **DO NOT** run vacuum over cord. Keep cord away from heated surfaces.
8. **DO NOT** handle the plug of the vacuum with wet hands.
9. Keep hair, loose clothing, fingers, and all parts of body away from openings and moving parts.
10. Use extra care when cleaning on stairs.
11. **DO NOT** put any objects into the openings. **DO NOT** use with any opening blocked; keep free of dust, lint, hair and anything that may reduce air flow.
12. **DO NOT** pick up anything that is burning or smoking, such as cigarettes, matches, or hot ashes.
13. **DO NOT** use without disposable paper filter bag, cartridge filter and filter cassette in place.
14. **DO NOT** vacuum water or liquids.
15. **DO NOT** use where oxygen or anesthetics are used.
16. Turn **OFF** all the controls before unplugging
17. **DO NOT** use an extension cord unless absolutely necessary. If an extension cord is used, then wire size must be #14 or larger and should not exceed 50 feet in length. The extension cord must be a three-wire type to insure grounding protection.
18. Replace damaged or worn parts immediately with genuine original equipment parts to maintain safety and to protect your limited warranty.

This vacuum must be connected to a properly grounded outlet only. (See *grounding instructions page 3*)

SAVE THESE INSTRUCTIONS

DANGER:

Improper use of the grounding plug can result in a risk of electric shock.

Electrical equipment must be grounded. If it should malfunction or breakdown, grounding provides a path of least resistance for electrical current to reduce the risk of electric shock. This vacuum is equipped with a cord having an equipment-grounding conductor and grounding plug. The plug must be inserted into an appropriate outlet that is properly installed

and grounded in accordance with all local codes and ordinances.

If repair or replacement of the cord or plug is necessary, DO NOT connect the grounded wire to either flat blade terminal. The wire with insulation having an outer surface that is green with or without yellow stripes is the grounding wire.

GROUNDING INSTRUCTIONS

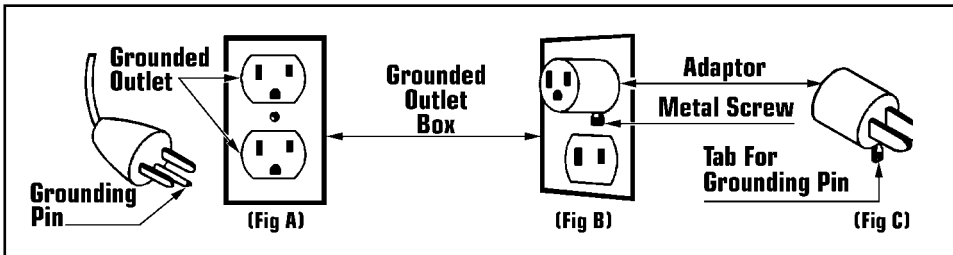

This electric equipment is for use on a nominal 120 volt circuit, and has a grounded plug that looks like the plug illustrated in (Fig A). A temporary adaptor that looks like the adaptor illustrated in (Fig B & C) may be used to connect this plug to a 2-pole receptacle as shown in (Fig B) if a properly grounded outlet is not available.

The temporary adaptor should be used only until a properly grounded outlet (Fig A) can be installed by a qualified electrician. The green color rigid ear, lug or the like extending from the adaptor must be connected to a permanent ground such as a properly grounded outlet box cover. Whenever the adaptor is used, it must be held in place by a metal screw. (Fig C)

GROUNDING METHODS

WARNING:

Improper connection of the equipment-grounding conductor can result in a risk of electric shock. Check with a qualified electrician or service person if you are in doubt as to whether the outlet is properly grounded. DO NOT modify the plug provided with the equipment. If it will not fit the outlet, have a proper outlet installed by a qualified electrician.

Note: In Canada, the use of a temporary adaptor is not permitted by the Canadian Electrical Code.

This vacuum has been specifically designed for use in hospital clean rooms. Special filters reduce the incidence of airborne dust that would be created by other methods of cleaning.

During removal of contaminated dust, DO NOT sweep, scoop, shovel or in any manner handle other than by vacuuming.

DO NOT at any time attempt to remove, substitute, bypass or by any other means change the filters in the vacuum.

Use only manufacturer's approved vacuum filters and filters bags.

Before attempting to use or before cleaning with this vacuum, be sure that you fully understand the instructions for setting up or cleaning/changing filters.

Any health hazards associated with use of this vacuum in conjunction with the removal of contaminated material has not been investigated by Underwriters Laboratories, Inc.

INTENDED USE OF THIS VACUUM

OPERATION OF THE VACUUM



The vacuum, filters and attachments are shipped together in one carton. Open the carton, remove the vacuum and attachments.



1) Make sure the power cord is passed through the power cord relief.



2) Release the clamp located in the back of the tank and lift off the motor head.

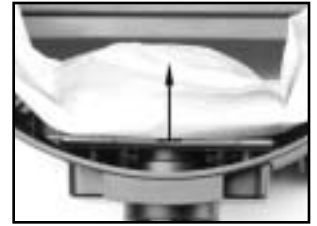

3) Check to see that the paper filter bag is properly installed (see page 5).



4) Close vacuum by sliding the slot in tank through the opening in the vacuum cover. Snap down clamp at the back of the tank.



5) The ON/OFF switch is located on top of the vacuum and lights up when the vacuum is plugged in.



6) When not in use wrap the cord around the hooks for convenient storage.



7) Install the hose to the vacuum inlet with a push motion, insert wand into the opposite end of hose and install cleaning tool required.

CAUTION:

Contaminated materials must be disposed of properly. NEVER throw contaminated debris in your usual trash receptacle. Place debris in a OSHA approved poly bag dispose in accordance with your local Hazardous Waste Regulations.

CAUTION:

Always unplug the vacuum from the power source before changing filters.

REMOVAL AND INSTALLATION OF PAPER FILTER BAGS

Check the paper filter bag each time you use the vacuum. It should be change when it is $\frac{3}{4}$ full to prevent breakage or spills.



Paper Filter Bag Removal

- 1) Remove the motor head and set aside.
- 2) Remove vacuum hose from the tank.
- 3) Pull up on the cardboard tab (shown) to close bag opening.
- 4) Slide bag up off the holder.
- 5) Fold the ends of the filter bag together, carefully remove it from the tank.
- 6) Dispose of the filter bag in accordance to local regulations.



Paper Filter Bag Installation

- 1) Remove the motor head and set aside
- 2) Remove vacuum hose from the tank.
- 3) Slide the filter bag down into the holder.
- 4) Fold top of bag back so it will not interfere when the motor head is replaced.



Change the outlet filter periodically.

Replacing Outlet Filter Cassette

- 1) Remove the outlet filter from the holder. **DO NOT** clean it.
- 2) Install a new filter in the holder and insert the holder into the motor head.

REPLACING OUTLET AND MOTOR FILTER



Replace the motor head filter when loss of vacuum occurs after you have checked for obstructions in the hose or wand.

Replacing Motor Filter

- 1) Turn the motor head upside down and slide the filter off.
- 2) Slide a new filter on to the motor as shown.
- 3) Right the current date on the filter date label.

CAUTION:

Never operate the vacuum cleaner without the motor filter, outlet filter and disposable paper bag in place. Motor damage and loss of operating efficiency that provide a clean air environment can occur.

ENVIORMASTER 9 REPLACEMENT PARTS LIST



Tool Kit

<i>Ref No</i>	<i>Part Description</i>	<i>Qty</i>	<i>Part No</i>
48	Crevice Tool	1	458333
49	Dusting Brush	1	458341
50	Floor Tool	1	459356
51A	Wand	1	459364
51B	Curved Wand Elbow	1	459399
52	Vinyl Hose	1	460052

Optional Filters

<i>Ref No</i>	<i>Part Description</i>	<i>Qty</i>	<i>Part No</i>
1	Standard Filter Cassette	1	458708
2	Standard Filter Cartridge	1	458716
3	Allergy Grade Filter Cassette	1	458724
4	Allergy Grade Filter Cartridge	1	458732
5	Hospital Grade Filter Cassette	1	458740
6	Hospital Grade Filter Cartridge	1	458937

Vacuum Parts List

<i>Ref No</i>	<i>Part Description</i>	<i>Qty</i>	<i>Part No</i>
1	Receptacle Outlet	1	457884
2	Wand Lock	2	399728
3	4 X 10 Screw	4	333948
4	Top Cover	1	457922
5	Felt Gasket	1	457930
6	5 X 14 Screw	18	457949
7	Motor Base Felt Basket	1	457957
8	Upper Pressure Switch	1	457965
9	Motor Housing Felt	1	457973
10	Paper Filter Bag (10/Pk)	1	457981
11	#PT Wn1412KB 60 X 25 Screw	1	458007
12	Paper Filter Bag Holder	1	458015
13	Vacuum Tank	1	458023
14	Right Caster Bracket	1	458031
15	Vacuum Inlet	1	458058
16	Insert Adaptor	1	458414
17	Rubber Double Casters	2	458422
18	Cable Restrain Assembly	1	458066
19	4-P Switch w/Light	1	457876
20	Carry Handle	1	458074
21	Power Cord	1	472972
22	Receptacle Outlet	1	458090
23	Hi-Low Switch	1	458104
24	PT WN1412KB 60 X 25 Screw	1	458120
25	Cartridge Filter Clip	1	458139
26	Cable Hook	1	458147
27	HEPA Red Filter Cassette	1	458115
28	Power Cord Holder	2	458163
29	Filter Cassette Gasket	1	458171
30	Side Foam	1	458198
31	Motor Cover	1	458201
32	Bumper	2	458228
33	Round Motor Gasket	1	458236
34	Small Motor Gasket	1	458244
35	Motor	1	458252
36	Bottom Motor Gasket	1	458260
37	Large Bottom Motor Gasket	1	458279
38	Motor Housing	1	458287
39	Filter Cartridge	1	458295
40	M5 Nylon Nut	2	458309
41	Clamp Assembly	1	458317
42	5M X 12 Screw	2	458325
43	Left Caster Bracket	1	458368
44	Rear Caster Bearing	2	458384
45	Rear Caster (Non-Marking)	2	458392
46	Spacer	1	458376
47	Caster Socket	2	458406

ENVIORMASTER 9 REPLACEMENT PARTS DRAWING

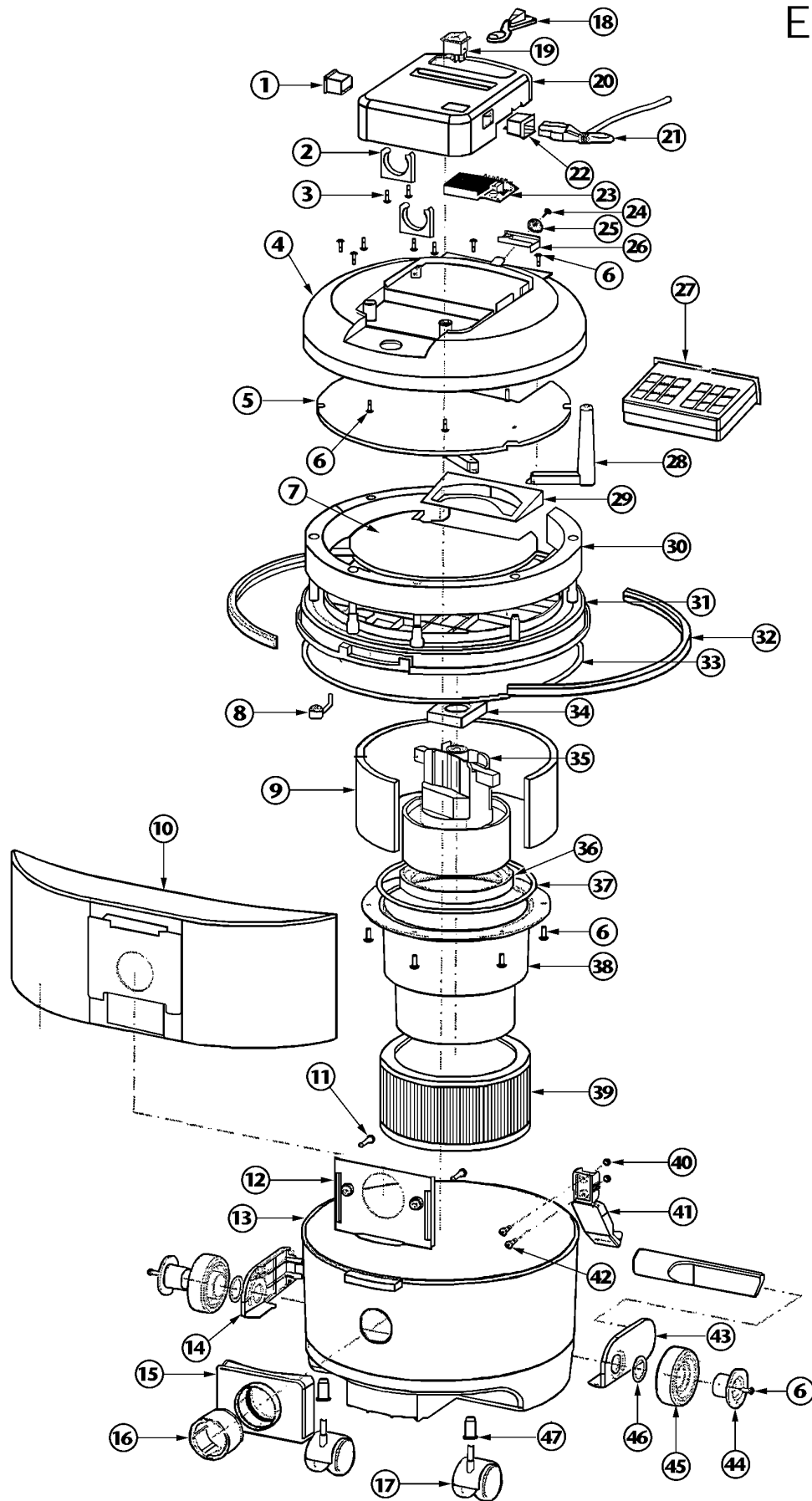

TROUBLE SHOOTING GUIDE

PROBLEM: Loss of Vacuum.

CAUSE:

1. Full paper disposable filter bag.
2. Clogged hose or wand.
3. Tank rim damaged.
4. Loose or broken fan.
5. Motor not working.

SOLUTION:

1. Replace disposable paper filter bag.
2. Remove obstruction.
3. Replace tank.
4. Contact manufacturer or service center.
5. Contact manufacturer or service center.

PROBLEM: Motor is not running.

CAUSE:

1. Broken switch.
2. Power cord defective.
3. Motor defective.
4. Blown fuse or tripped circuit breaker.

SOLUTION:

1. Contact manufacturer or service center.
2. Contact manufacturer or service center.
3. Contact manufacturer or service center.
4. Replace fuse or reset circuit breaker.

PROBLEM: Dust blowing from vac when running.

CAUSE:

1. Full paper disposable filter bag.
2. Paper filter bag not installed properly or off inlet tube.
3. Disposable paper filter bag is torn.

SOLUTION:

1. Replace disposable filter bag.
2. Reinstall disposable paper filter.
3. Replace disposable filter bag.



Address:

777 South Street P.O. Box 2310, Newburgh, N Y 12550-0606

TEL:

(800) 835-7812 (845) 565-8850

FAX:

(800) 752-6883 (845) 565-9392

Internet Access:

www.mastercraftusa.com